

MMP

Medium-Duty Precleaner

Extra Cleaning Power for Tough Jobs

The MMP Medium-Duty Precleaner tackles those tough applications where the standard-duty precleaner is not sturdy enough but the heavy-duty cleaner is overkill. The MMP is built tough with a heavy-duty pole, a larger, powerful blade and a beefy dual tensioning system. Yet installation is simple, maintenance is quick, and bottom line—the cleaning job is excellent.

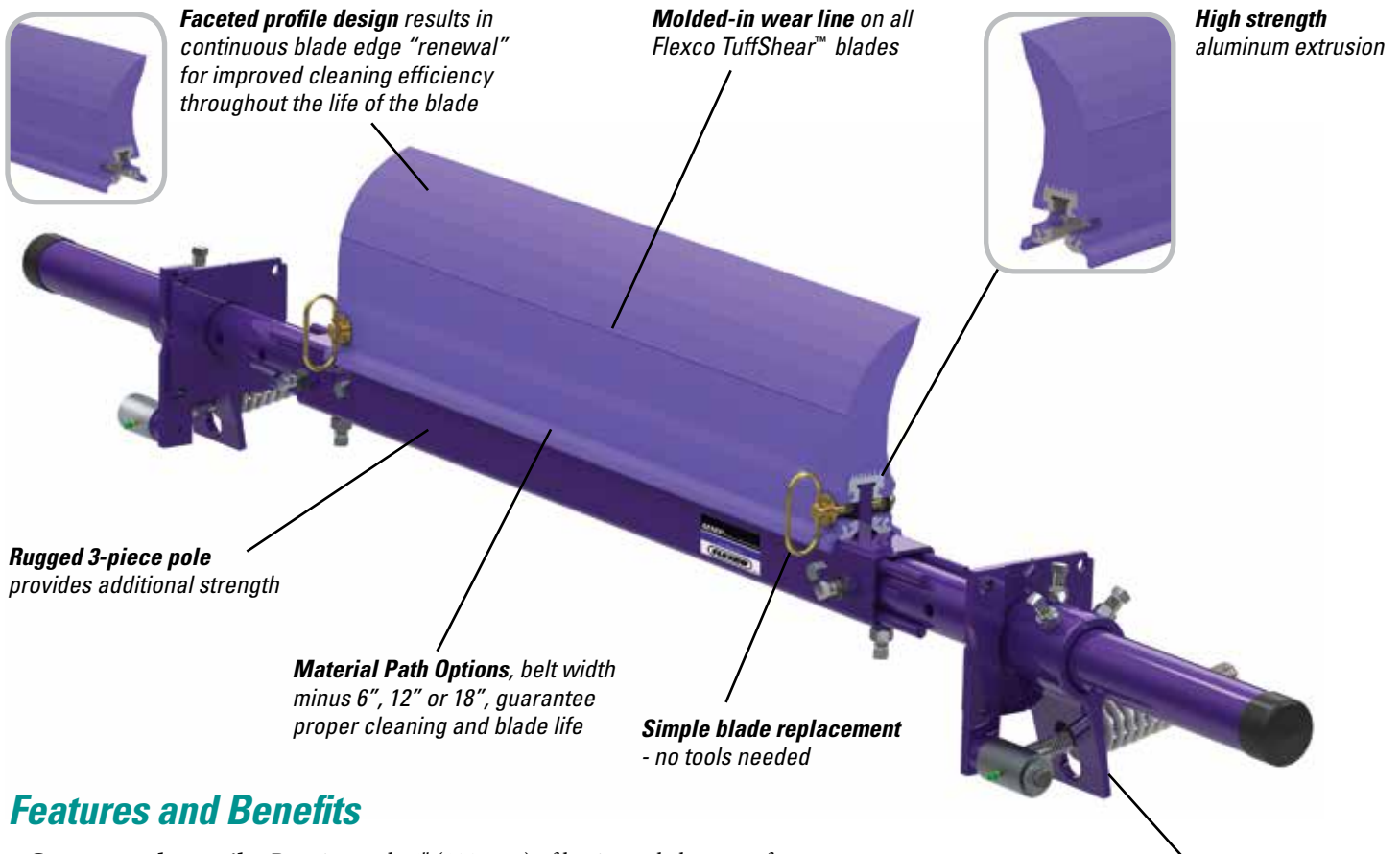

Features and Benefits

- **Compact and versatile.** Requires only 4" (100 mm) of horizontal clearance for installation. Pole length is belt width plus 54" (1350 mm) to fit varying conveyor or chute wall widths. Pole extenders are available for extended length requirements.
- **Works with Flexco and other mechanical splices.** The spring tensioner quickly moves the blade away from the belt when a splice passes. The polyurethane blade easily glides over the splice without damage and with minimal cleaning disruption.
- **Made for mining conveyors.** Made from heavy-duty steel with corrosion-resistant powder coating, the MMP is available for belt widths from 24" to 96" (600 to 2400 mm). Special sizes are available upon request.
- **Complete cleaning system.** When teamed with our MHS Secondary Cleaner, it makes up a system that delivers maximum cleaning power. If extra water is present, the MDWS DryWipe can be added.

MMP Medium-Duty Precleaner

Specifications and Guidelines

- **Maximum Belt Speed**
1000 FPM (5 M/sec)
- **Temperature Rating**
-30°F to 180°F (-35°C to 82°C)
- **Minimum Pulley Diameter**
16" (400 mm)
- **Blade Height**
10" (250 mm)
- **Usable Blade Wear Length**
6" (150 mm)
- **Blade Material**
Urethane 83 durometer (proprietary blend for abrasion resistance and long wear)
- **Available for Belt Widths**
24" to 96" (600 to 2400mm)
- **Horizontal Clearance Required**
4" (100mm)
- **Vertical Clearance Required**
13" (325mm)
- **CEMA Cleaner Rating**
Class 4
- **Pole Length**
Cleaner size + 54" (1350mm)
- **Maximum Conveyor Span**
Cleaner size + 42" (1050mm)

Pole Location Specs

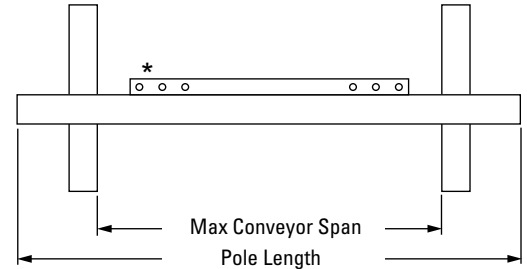
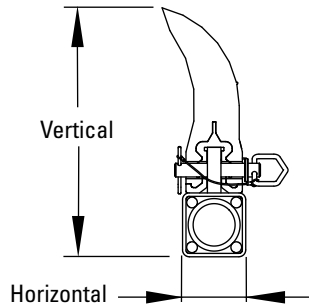
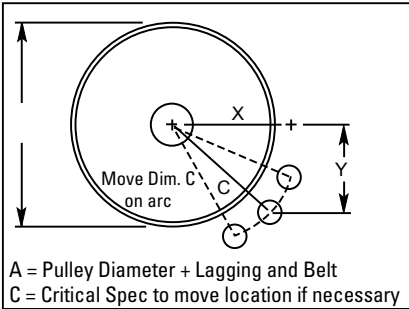

Pole Location Chart

A	X	Y	C	A	X	Y	C	A	X	Y	C
16"	8-1/8"	12"	14-1/2"	27"	14-1/8"	12"	18-1/2"	38"	19-3/4"	12"	23-1/8"
17"	8-3/4"	12"	14-7/8"	28"	14-5/8"	12"	18-7/8"	39"	20-3/8"	12"	23-5/8"
18"	9-1/4"	12"	15-1/8"	29"	15-1/4"	12"	19-3/8"	40"	20-3/4"	12"	24"
19"	9-3/4"	12"	15-1/2"	30"	15-5/8"	12"	19-3/4"	41"	21-3/8"	12"	24-1/2"
20"	10-3/8"	12"	15-7/8"	31"	16-1/8"	12"	20-1/8"	42"	21-3/4"	12"	24-7/8"
21"	11"	12"	16-1/4"	32"	16-3/4"	12"	20-5/8"	43"	22-3/8"	12"	25-3/8"
22"	11-1/2"	12"	16-5/8"	33"	17-1/4"	12"	21"	44"	22-3/4"	12"	25-3/4"
23"	12"	12"	17"	34"	17-3/4"	12"	21-3/8"	45"	23-3/8"	12"	26-1/4"
24"	12-5/8"	12"	17-3/8"	35"	18-1/4"	12"	21-7/8"	46"	23-7/8"	12"	26-3/4"
25"	13-1/8"	12"	17-3/4"	36"	18-3/4"	12"	22-1/4"	47"	24-3/8"	12"	27-1/8"
26"	13-5/8"	12"	18-1/8"	37"	19-3/8"	12"	22-3/4"	48"	24-7/8"	12"	27-5/8"

Ordering Information

MMP Precleaner - Belt Width Minus 6"				
Belt Width	Blade Width	Ordering Number	Item Code	
in.	mm	in.	mm	
24	600	18	450	MMP-624 76450
30	750	24	600	MMP-630 76451
36	900	30	750	MMP-636 76452
42	1050	36	900	MMP-642 76453
48	1200	42	1050	MMP-648 76454
54	1350	48	1200	MMP-654 76455
60	1500	54	1350	MMP-660 76456
72	1800	66	1650	MMP-672 76457
84	2100	78	1950	MMP-684 76798
96	2400	90	2250	MMP-696 79033

MMP Precleaner - Belt Width Minus 12"				
Belt Width	Blade Width	Ordering Number	Item Code	
in.	mm	in.	mm	
30	750	18	450	MMP-1230 76551
36	900	24	600	MMP-1236 76552
42	1050	30	750	MMP-1242 76553
48	1200	36	900	MMP-1248 76554
54	1350	42	1050	MMP-1254 76555
60	1500	48	1200	MMP-1260 76556
72	1800	60	1500	MMP-1272 76557
84	2100	72	1800	MMP-1284 76799
96	2400	84	2100	MMP-1296 79034

TuffShear™ Replacement Blades			
Blade Width	Ordering Number	Item Code	
in.	mm		
18	450	TRB18	76485
24	600	TRB24	76486
30	750	TRB30	76487
36	900	TRB36	76488
42	1050	TRB42	76489
48	1200	TRB48	76490
54	1350	TRB54	76491
60	1500	TRB60	76492
66	1650	TRB66	76493
72	1800	TRB72	76494
78	1950	TRB78	76697
84	2100	TRB84	77047
90	2250	TRB90	77048

Other blade sizes available upon request.

Authorized Distributor:

Distribution in Europe by:
Flexco Europe GmbH • Leidringer Strasse 40-42 • D-72348 Rosenfeld • Germany
Phone: +49-7428-9406-0 • Fax: +49-7428-9406-260 • E-mail: europe@flexco.com • Web: www.flexco.com

